



川源(中国)机械有限公司
GSD (China) Co., Ltd.



JBJ 桨式搅拌机

JBJ propeller mixer

JBJ 桨式搅拌机

JBJ propeller mixer

用途

- 用于水厂污泥池、絮凝池和工业流程中需要对固液进行溶解、均质的水上搅拌机械。

Usage

The paddle type mixer is composed by the power section, the foundation, the drive shaft and the blade and so on.

结构组成

- JBJ型桨式搅拌机由动力部分、底座、传动轴和叶板等组成。

The Structure

The JBJ paddle type mixer is composed by the power section, the foundation, the drive shaft and the blade and so on

型号说明 Type description

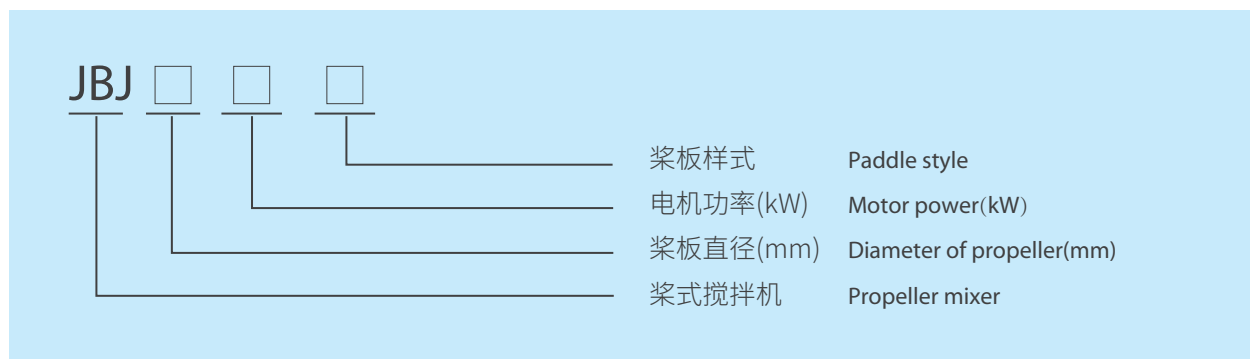

桨板样式默认为单层三叶桨，也可依据现场情况做双层双桨及特殊样式。

The paddle style defaults to single-layer three-leaf paddle, and double-layer double paddle and special style can also be made according to site conditions.

结构简图 Construction

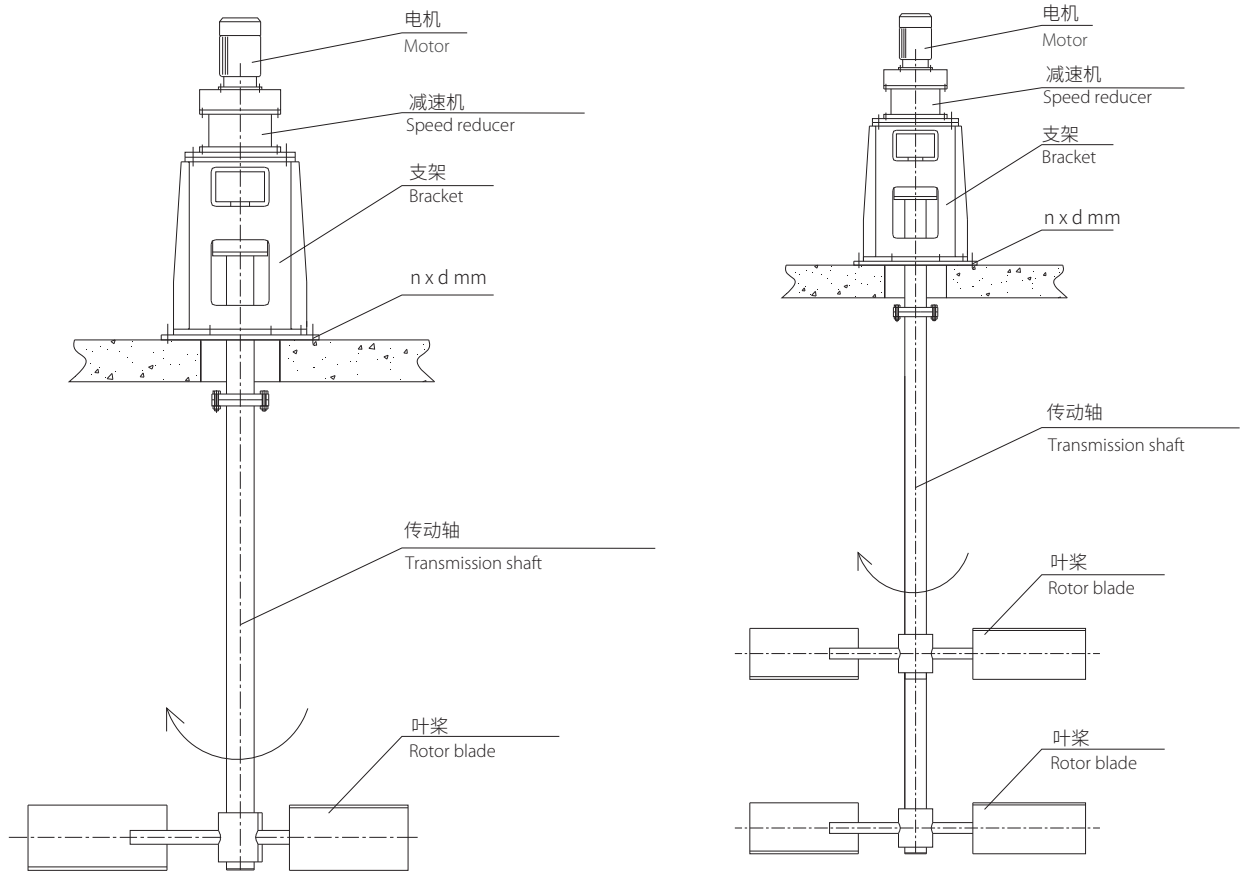

主要技术参数 Main Technical Parameters

参数尺寸 Parameters and dimensions	型号 Model	工作转速 Operating rotate speed r/min	电机功率 Motor power kW	L mm	D mm	n x d mm
	JBj350	88	0.37	按工况定	350	4x19
	JBj400	88	0.37	按工况定	400	4x19
	JBj450	52	0.37	按工况定	450	4x19
	JBj600	35	0.37	按工况定	600	4x19
	JBj600	52	0.55	按工况定	600	4x19
	JBj800	35	0.55	按工况定	800	4x19
	JBj550	88	0.75	按工况定	550	4x19
	JBj700	52	1.1	按工况定	700	4x19
	JBj900	35	1.1	按工况定	900	4x19

注：可根据用户要求作特殊设计

Note: Special design can be made in accordance with the demand of the users

桨式搅拌机外形安装图

Diagram of the outside dimensions and installation for propeller type mixer

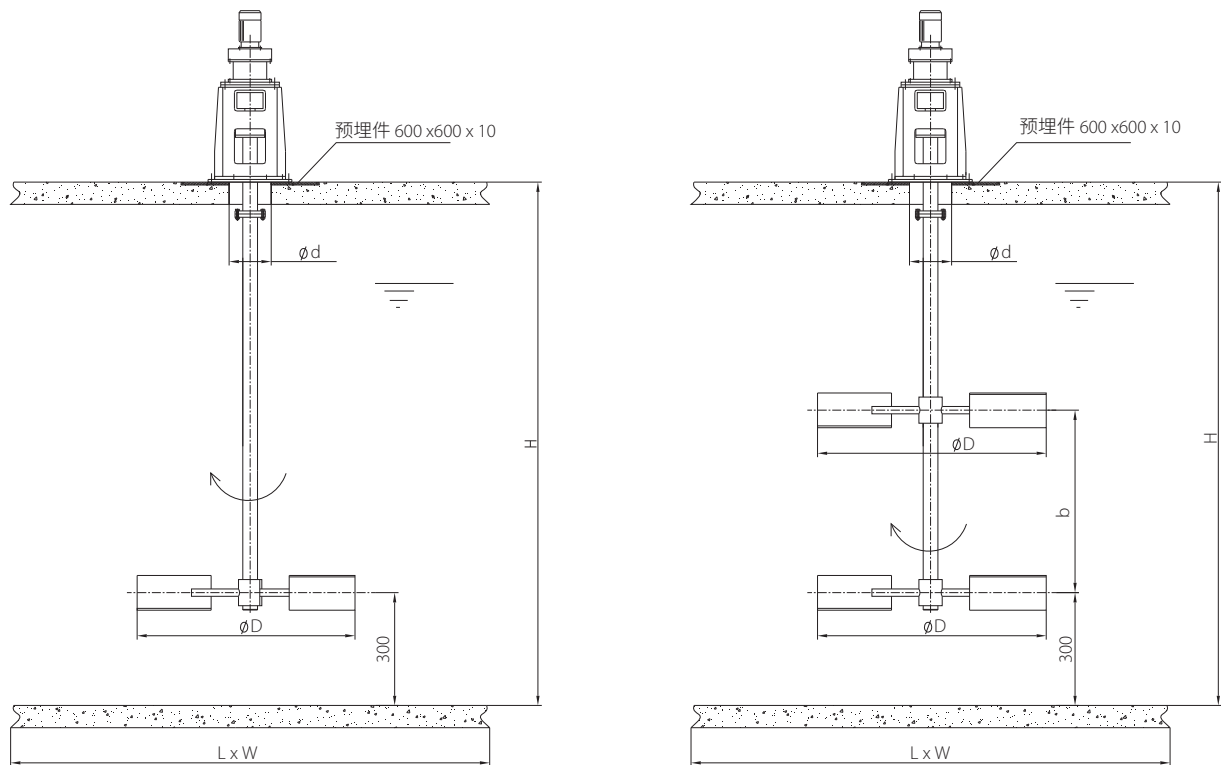

环保设备和技术服务的专业伙伴

免费咨询电话

400-657-9066

本型录内容如有变更，恕不另行通知。
We reserve the right to change content without notice.

川源(中国)机械有限公司版权所有 all rights reserved. CY-J8

